

W-150 HEAVY DUTY "A" AUTOMATIC

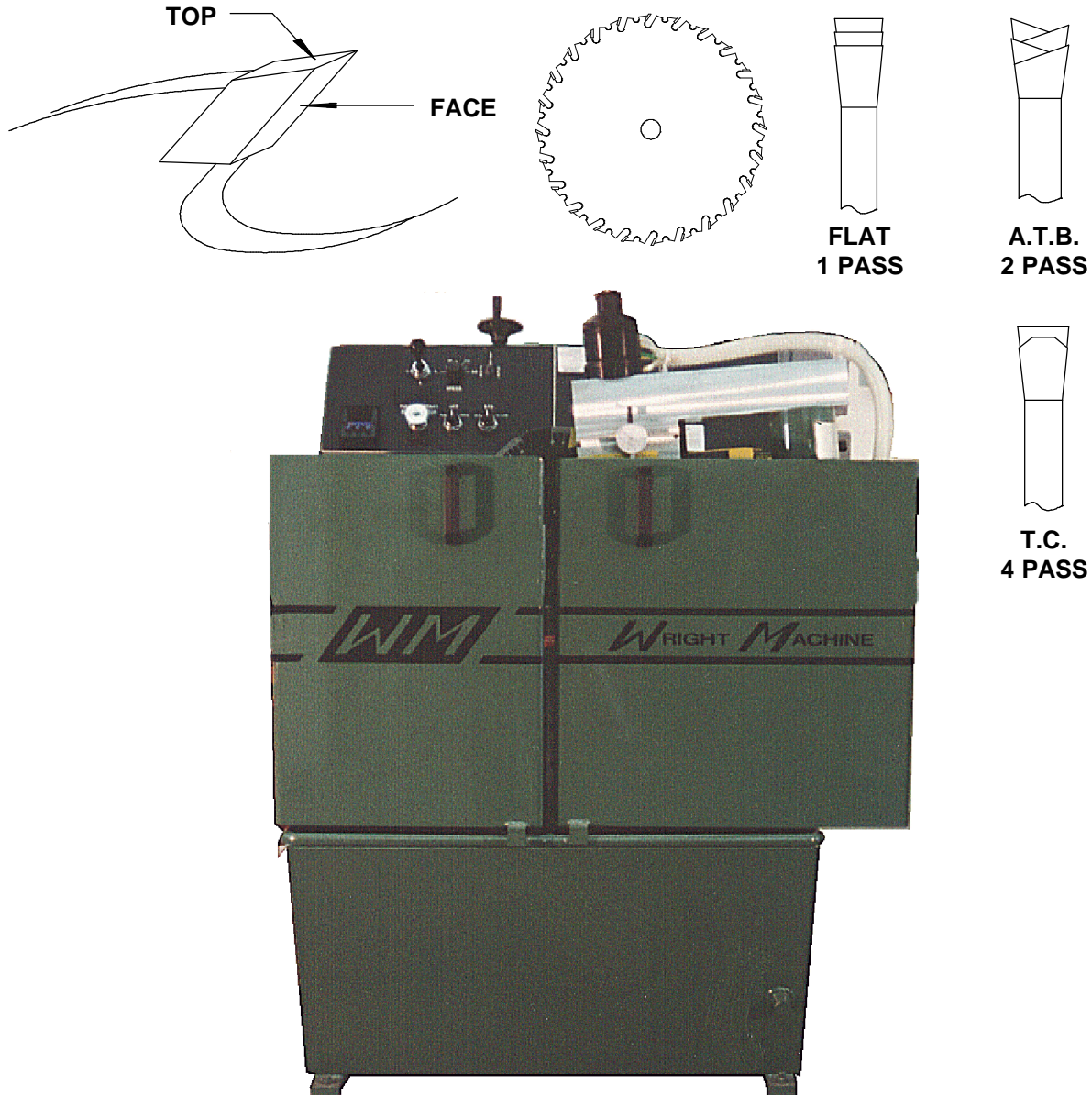

The Wright W-150 HD Sharpens the top or face of circular saws. Heavy duty construction increases accuracy, productivity, and machine life.

With such easy operation and maintenance you can count on the W-150 HD A's performance year after year.

Specifications and availability subject to change without notice.

SAW SHARPENING SYSTEMS

See us on the Internet at ...
WWW.WRIGHTTOOLS.COM

W-150 HEAVY DUTY "A" AUTOMATIC

Features

- FILTERED FULL FLOOD COOLANT
- TOOTH COUNTER WITH AUTO-STOP
- POLY RIB BELT DRIVE
- LOW VOLTAGE WORK LIGHT
- 1 H.P. SPINDLE MOTOR
- DUAL PRESSURE SAW CLAMP
- PRECISION SPINDLE
- LIFT-OFF GRIND
- SWING OPEN SPLASH DOORS

Technical

Improved saw sharpening accuracy is accomplished through lift off grind on return stroke, precision multi bearing spindle, heavy duty slide system, 1 horse power drive motor, and a massive construction design.

Operation is a snap due to the simple, easy to operate controls. Efficient operation becomes second nature.

Field proven performance, first introduced in 1985 and refined with continual improvements, the W-150 HD has become the "Industry Standard" top or face sharpener.

Specifications

Circle saw size	4" TO 30"
Power Consumption	1.5 kw
Air	1 C.F.M @ 80 P.S.I.
Voltage std.	230V 3PH 50/60
Ship Weight	1,425 LBS.
Crate Size	49" X 44" X 62"
Max. Pitch	4-1/4"

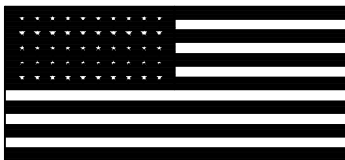

MADE IN U.S.A.
PRINTED IN U.S.A.
1995

WRIGHT MACHINE
365 PALMER AVE.
COTTAGE GROVE, OR.
97424
PHONE: 541-942-3712
FAX: 541-942-0730

Specifications and availability subject to change without notice.



See us on the Internet at ...
WWW.WRIGHTTOOLS.COM